



SY6912A

2A Multi-Cell High Efficiency Switching Charger

Preliminary Specification

General Description

SY6912A is a 4.0-23V input, 2A multi-cell synchronous Buck Li-Ion battery charger, suitable for portable application. Select pin is convenient for multi-cell charging. 800 kHz synchronous buck regulator integrates of 23V rating FETs with ultra low on-resistance to achieve high efficiency and simple circuit design.

Ordering Information

SY6912 □(□□)□

} Temperature Code
} Package Code
} Optional Spec Code

Temperature Range: -40°C to 85°C

Ordering Number	Package type	Note
SY6912AFCC	SO8E	

Features

- Wide Input Voltage Range: 4.0V to 23V
- High Efficiency Int. Synchronous Buck Regulator with Fixed 800kHz Switching Frequency
- Selectable for Multi-cell Charging
- Trickle Current / Constant Current / Constant Voltage Charge Mode
- Programmable (2A Max) Constant Charge Current
- Programmable Charging Timer
- Input Voltage UVLO and Battery OVP
- Over Temperature Protection
- Output Short Circuit Protection
- Automatic Shutdown Prevents Reverse Energy Flow
- Charge Status Indication
- Normal Synchronous Buck Operation when Battery Removed
- Compact package SO8E

Applications

- Cellular Telephones,
- PDA, MP3 Players, MP4 Players
- Digital Cameras
- Bluetooth Applications
- PSP Game Players, NDS Game Players
- Notebook

Typical Applications

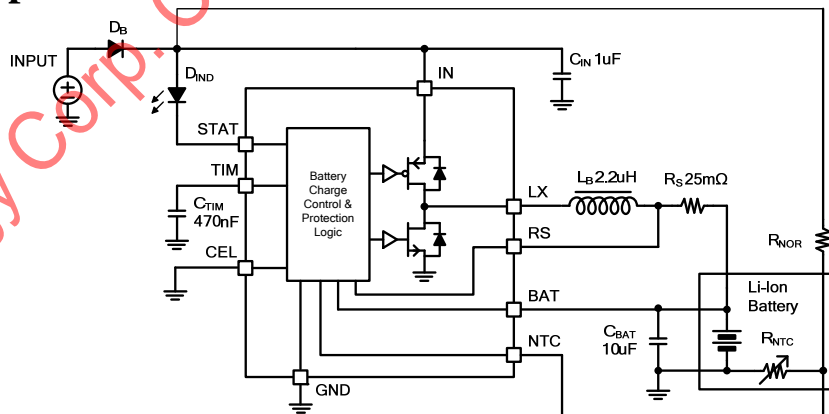
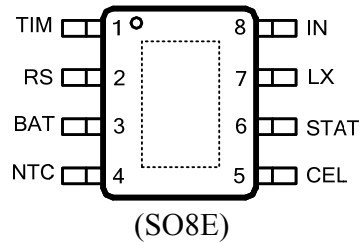

Figure 1. SY6912A Schematic Diagram

Pinout (top view)



Top Mark: AIQxyz (device code: AIQ, x=year code, y=week code, z=lot number code)

Name	Number	Description
RS	1	Charge current program pin. Connect a current sense resistor from RS pin to BAT pin. Average charge current is detected for both TC mode and CC mode.
BAT	2	Battery positive pin.
NTC	3	Thermal protection pin. UTP threshold is about 75%V _{IN} and OTP threshold is about 30%V _{IN} . Pull up to V _{IN} can disable charge logic and make the IC operate as normal buck regulator. Pull down to ground can shutdown the IC.
CEL	4	Pull down for single-cell, pull high for 2 cells, open for 3 cells.
STAT	5	Charge status indication pin. It is open drain output pin and can be used to turn on a LED to indicate the charge in process. When the charge is done, LED is off.
LX	6	Switch node pin. This pin connects the drains of the integrated main and synchronous power MOSFET switches. Connect to external inductor.
IN	7	Positive power supply input pin. V _{IN} ranges from 4V to 23V for normal operation. It has UVLO function and must be 300mV greater than the battery voltage to enable normal operation.
TIM	8	Charge time limit pin. Connect this pin with a capacitor to ground. Internal current source charge the capacitor for TC mode and CC mode's charge time limit. TC charge time limit is about 1/9 of CC charge time.
GND	Exposed pad	Ground pin.

Absolute Maximum Ratings (Note 1)

CEL, NTC, STAT,	-0.5-32V
IN, BAT, LX,	-0.5- 23V
TIM,	-0.5- 3.6V
RS,	BAT-0.3~BAT+0.3
LX Pin current continuous	2A
Power Dissipation, P _D @ T _A = 25°C, SO8E.....	3.3W
Package Thermal Resistance (Note 2)	
θ _{JA}	30°C/W
θ _{JC}	20°C/W
Junction Temperature Range	-40°C to 125°C
Lead Temperature (Soldering, 10 sec.)	260°C
Storage Temperature Range	-65°C to 125°C

Recommended Operating Conditions (Note 3)

CEL, NTC, STAT,	less than 32V
IN, BAT, LX,	less than 23V
TIM,	less than 3.6V
RS,	in the range of BAT-
0.3~BAT+0.3LX Pin current continuous	less than 2A
Junction Temperature Range	-20°C to 100°C
Ambient Temperature Range	-40°C to 85°C



Electrical Characteristics

T_A=25°C, V_{IN}=15V, GND=0V, C_{IN}=1uF, L_B=2.2uH, R_S=25mΩ, C_{TIM}=470nF, unless otherwise specified.

Symbol	Parameter	Conditions	Min	Typ	Max	Unit
Bias Supply (V_{IN})						
V _{IN}	Supply voltage		4.0		23	V
V _{UVLO}	V _{IN} under voltage lockout threshold	V _{IN} rising and measured from V _{IN} to GND			3.9	V
ΔV _{UVLO}	V _{IN} under voltage lockout hysteresis	Measured from V _{IN} to GND		190		mV
V _{OV}	Input overvoltage protection	V _{IN} rising and measured from V _{IN} to GND			24	V
ΔV _{OV}	Input overvoltage protection hysteresis	Measured from V _{IN} to GND		750		mV
Quiescent Current						
I _{BAT}	Battery discharge current	NTC pull down to GND			25	uA
I _{IN}	Input quiescent current	Disable Charge			2.0	mA
Oscillator and PWM						
f _{OSC}	Oscillator frequency		640	800	960	kHz
D	PFET duty cycle				100	%
Power MOSFET						
R _{NFET}	R _{DS(ON)} of N-FET			150		mΩ
R _{PFET}	R _{DS(ON)} of P-FET			160		mΩ
Voltage Regulation						
V _{CV}	Single-cell CV charge mode	0°C <=T _A <=70°C	4.16	4.20	4.24	V
	2-cell CV charge mode		8.32	8.40	8.48	
	3-cell CV charge mode		12.48	12.60	12.72	
ΔV _{RCH}	Single-cell Voltage threshold for Recharge	0°C <=T _A <=70°C	50	100	150	mV
	2-cell Voltage threshold for Recharge		100	200	300	
	3-cell Voltage threshold for Recharge		150	300	450	
V _{TRK}	Single-cell TC charge mode voltage threshold	0°C <=T _A <=70°C	2.2	2.5	2.8	V
	2-cell TC charge mode voltage threshold		4.4	5.0	5.6	
	3-cell TC charge mode voltage threshold		6.6	7.5	8.4	
Battery Connect Detection						
V _{DET}	Detect voltage threshold	V _{SHOT} < V _{BAT} < V _{RCH}	80%		90%	V _{IN}
t _{DET}	Detect delay time			30		
Charge Current						
	Internal charge current accuracy for Constant Current Mode	I _{CC} =25mV/R _S	-10%		10%	
	Internal charge current accuracy for Trickle Current Mode	I _{TC} =2.5mV/R _S	-50%		50%	
Output Voltage OVP						
V _{OV}	Output voltage OVP threshold		108%	113%	118%	V _{CV}
Output Short Protection						
V _{SHOT}	Output short protection threshold	V _{BAT} falling edge	1.70	2.00	2.30	V
f _{FBK}	Frequency fold back	V _{BAT} <2V		12.5%		f _{OSC}
I _{LM}	Power FET current limit			4.0		A
Timer						
T _{TC}	Trickle current charge timeout	C _{TIM} =330nF	0.23	0.5	0.67	hour
T _{CC}	Constant current charge timeout		3.0	4.5	6.0	hour
T _{MC}	Charge mode change delay time			30		ms
T _{TERM}	Termination delay time			30		ms
T _{RCHG}	Recharge time delay			30		ms
Battery Thermal Protection NTC						
UTP	Under temperature protection		70%	75%	80%	V _{IN}
	Under temperature protection hysteresis	Falling edge		5%		
OTP	Over temperature protection		28%	30%	32%	
	Over temperature protection hysteresis	Rising edge		2%		
Automatic Shutdown						
ΔV _{ASD}	ASD voltage threshold hysteresis	Measured from V _{IN} to V _{BAT}	140	280	420	mV

Note 1: Stresses beyond the “Absolute Maximum Ratings” may cause permanent damage to the device. These are stress ratings only. Functional operation of the device at these or any other conditions beyond those indicated in the operational sections of the specification is not implied. Exposure to absolute maximum rating conditions for extended periods may affect device reliability.

Note 2: θ_{JA} is measured in the natural convection at $T_A = 25^\circ\text{C}$ on a low effective four-layer thermal conductivity test board of JEDEC 51-3 thermal measurement standard.

Note 3: The device is not guaranteed to function outside its operating conditions

Basic Li-Ion Battery Charge Operation Flow Chart

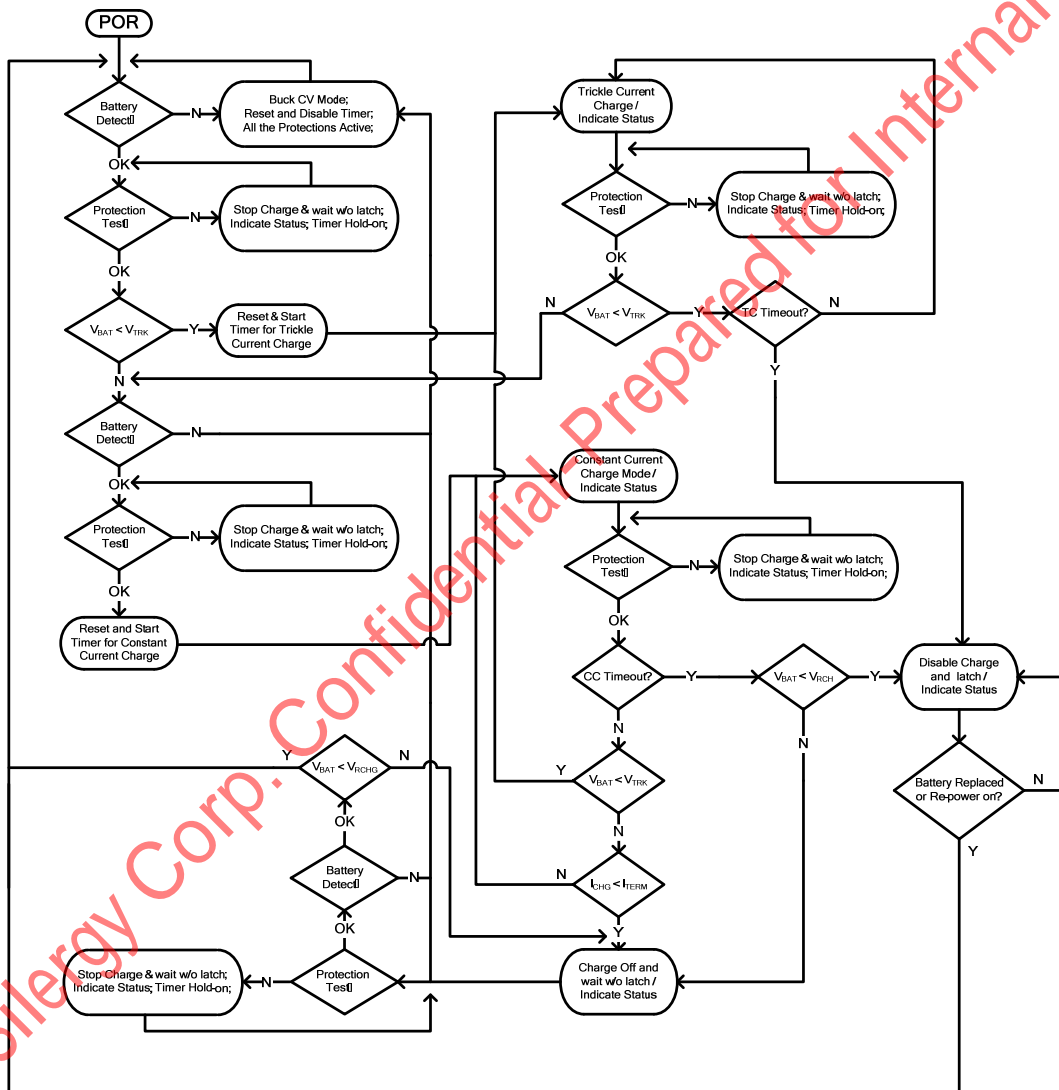



General Function Description

SY6912A is a 4.0-23 input, 2A multi-cell synchronous buck Li-Ion battery charger, suitable for portable application. Select pin is convenient for multi-cell charging. Integrated 800 kHz synchronous buck regulator consists of 23V rating FETs with extremely low on-resistance to achieve high charge efficiency and simple circuit design.

Charging Status Indication Description

1. **Charge-In-Process** – Pulls and keeps STAT pin to Low;
2. **Charge Done** – Pulls and keeps STAT pin to High;
3. **Fault Mode** – Outputs high and low voltage alternatively with 0.5Hz frequency.

Connects a LED from VIN to STAT pin, **LED ON** indicates **Charge-in-Process**, **LED OFF** indicates **Charge Done**, **LED Flash** indicates **Fault Mode**.

Buck Regulator Operation Description

If the Li-Ion battery is removed suddenly, the voltage on NTC pin increases higher than 90% V_{in} . Then, it operates as a normal peak current mode controlled synchronous buck converter and the output voltage on BAT pin is regulated at V_{CV} . In this operation mode, the constant output current loop is still active, however the charge timeout and the trickle current charge are disabled.

Protection Description

Thermal Protection-Thermal shutdown is active for both battery and IC. IC resumes normal work when the temperature backs in normal range again.

Short Circuit Protection- When V_{BAT} voltage is lower than the short circuit protection threshold, short circuit protection is active. In charger operation mode, the switching frequency is folded back to 12.5% of the default value and VC is folded back to 20% of the maximum value. The trickle charge timer is still active and would timeout the IC finally. In Buck operation mode, the switching frequency is folded back to 12.5% of the default value, and the VC initiates softstart periodically.

Over Current Protection-The internal current loop with different constant current capability is always active no matter in Buck mode or Battery Charging mode for the over current protection.

Over Voltage Protection-When V_{BAT} voltage is higher than the over voltage protection threshold no matter with or without battery connecting, IC shuts down and recovers to normal work when V_{BAT} backs to normal level. Input voltage has UVLO and OVP, which would make IC shutdown and recover to normal work when the V_{IN} backs to normal range.

Timeout Protection-Programmable timeout protection is for both Trickle Current Charge Mode and Constant Current Charge Mode. Once timeout is active, IC stops the charge operation and latches off. Only power or battery re-plug in can get the latch logic reset and the IC restarted.

SO8E Package outline & PCB layout design

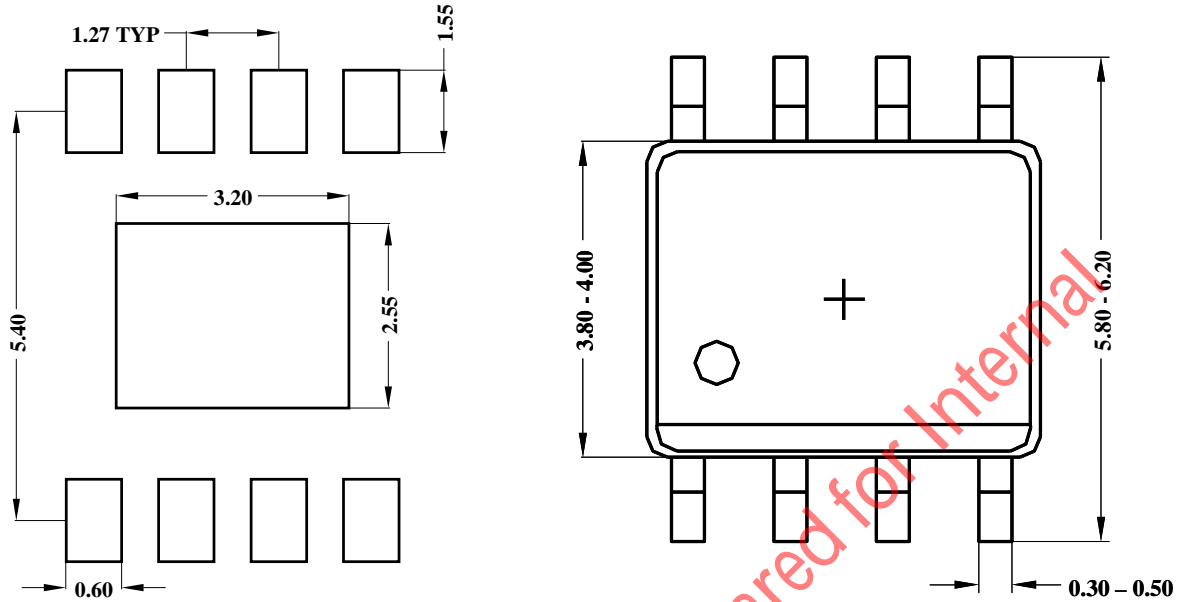

Recommended Pad Layout

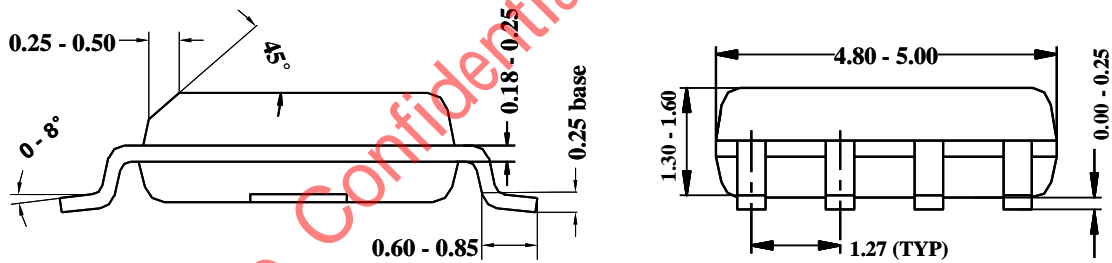

Notes: All dimensions are in millimeters.
All dimensions don't include mold flash & metal burr.

Taping & Reel Specification

1. Taping orientation

SO8E

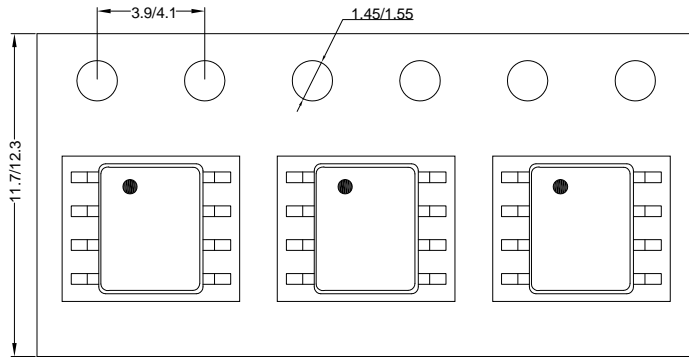

Feeding direction →

2. Carrier Tape & Reel specification for packages

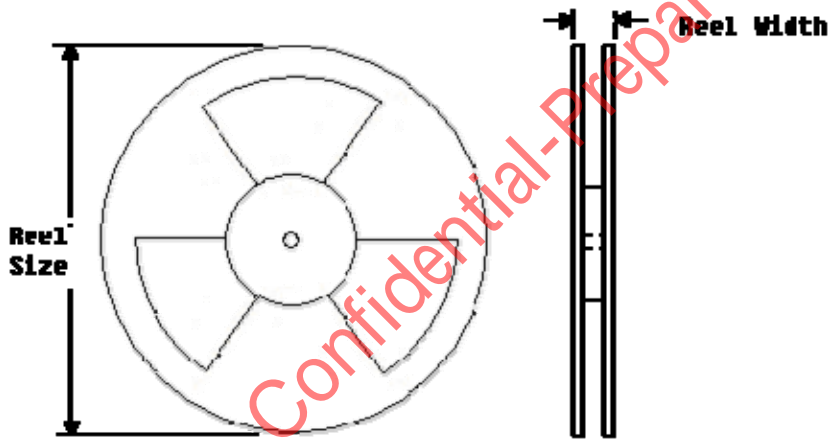

Package types	Tape width (mm)	Pocket pitch(mm)	Reel size (Inch)	Reel width(mm)	Trailer length(mm)	Leader length (mm)	Qty per reel
SO8E	12	8	13"	12.4	400	400	2500

3. Others: NA